

SPECIFICATIONS

Weight capacity: 3 persons / 985 lbs.
 Max HP: 6 HP / 65 lbs. / Short shaft (15")
 Hull weight: 75 lbs.
 Air chambers: 3 + keel + floor
 Fabric: PVC 0.9 mm
 Factory warranty: 3 years recreational / 1 year commercial

SEC FEATURES

- 1.- A Two double carry handle
- 2.- A 6 interior tie down D-rings (Stainless steel)
- 3.- A Inflation and over inflation valves
- 4.- A Non-skid high pressure air floor
- 5.- A 4 carry handles, non slip design
- 6.- A Oar locks
- 7.- A 2 seat (2 positions)
- 8.- A Reinforcement on tube transom attachments
- 9.- A Interior transom lifting rings (Stainless steel)
- 10.- A Exterior transom eyes
- 11.- B Interior aluminum engine mounting plate
- 12.- B Marine plywood transom
- 13.- B Standard self bailer with plug (Pop-up design)
- 14.- C All around (Side protection) rub strake, flat profile
- 15.- C Bow handle (Stainless)
- 16.- C Two large tow rings on bow (Stainless steel)
- 17.- C Rubbing strakes for beaching on keel

ACCESSORIES

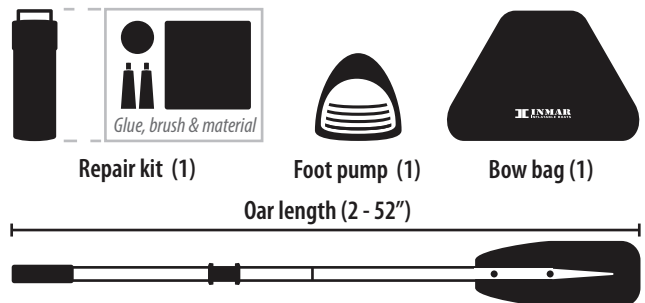

SHIPPING INFORMATION



BOAT

- Package dimensions: 45x27x15 (0.26 cbm.)
- Package weight: 119 lbs.

OPTIONAL EQUIPMENT:

- Quick-Fill field inflation system (SCUBA or SCBA)
- Scuppers set (High volume water drainage)
- Solas reflective panels (High night visibility)